

LIQUID LEVEL GAUGES

K9900 LEVEL GAUGE WITH INTEGRAL VALVES AND MISALIGNMENT UNIONS

"PATENT PENDING"

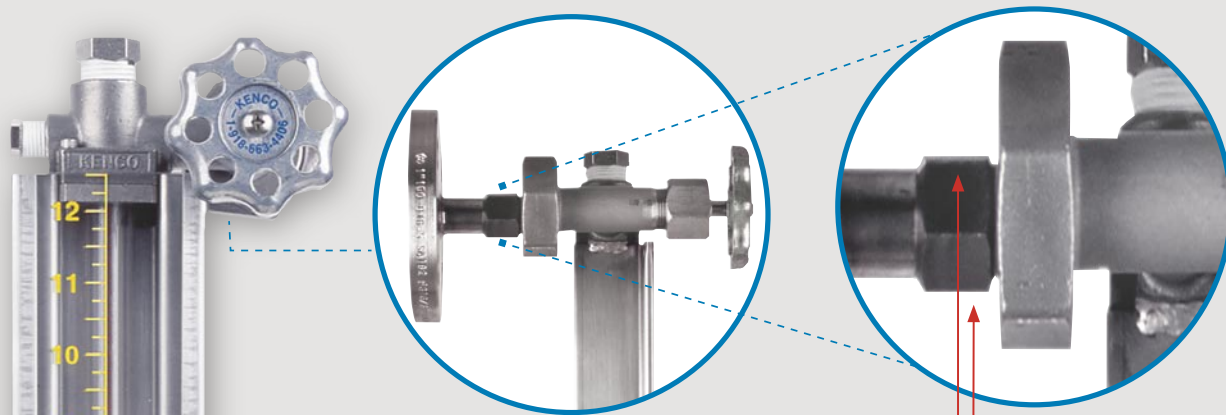

NEW, FLOATING MISALIGNMENT UNIONS ALLOW PROCESS CONNECTION CENTERLINES TO VARY +/- 1/4"

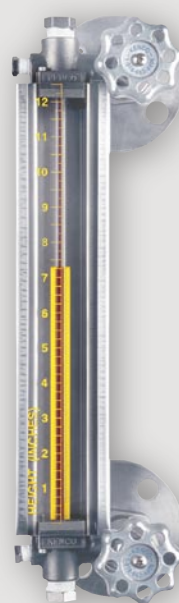

K99 Bulk Tank Gauge w/Optional Flange Connection



K9957 Bulk Tank Gauge w/ Integral Valve on Bottom w/Threaded Connection on Top

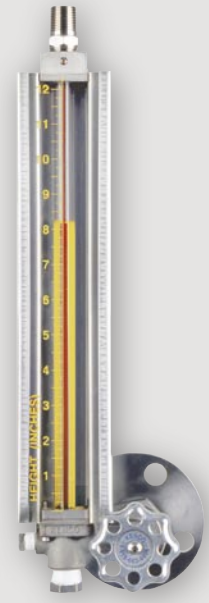

K9957 Bulk Tank Gauge w/Optional Flange Connection

The patented K9900 Series Level Gauge features an innovative casting design which will simplify the installation process and eliminate other typical problems associated with gauge glasses. The K9900 incorporates floating misalignment unions, which will allow process connection centerlines to vary +/- 1/4". The gauge also has integral offset pattern valves with ball check shutoffs. 1/2" vent and drain connections are inline for routine sight glass maintenance. The K9900 Series Level Gauge delivers a safe, low maintenance, cost effective solution to common sight glass applications.

APPLICATIONS

- Low to Medium pressure applications up to 500 psi
- Bulk storage tanks
- Marine
- Low pressure scrubbers and surge tanks
- Seal pots

PRODUCT FEATURES

- Floating misalignment unions allow process connection centerlines to vary +/- 1/4"
- Offset pattern check valves with ball check shutoffs
- Ball check shutoff valves protect tank inventory
- Tubular sight glass allows for easy viewing of liquid level
- Innovative casting design includes all necessary mounting components up to process connection
- Rugged armored gauge construction protects sight glass from mechanical impact
- 1/2" vent and drain ports for routine gauge glass maintenance
- Additional 1/4" port available for optional mounting of other instrumentation for level gauge monitoring
- Custom scales for tank volume or other calibrations are available
- Armored frame and polycarbonate shield protect operator in case of accident
- ABS and DNV certified for marine applications

K99 BULK TANK GAUGE

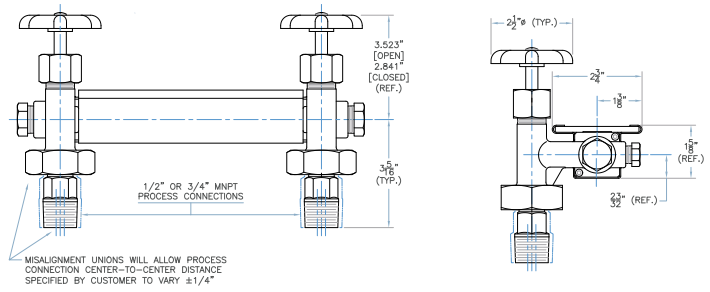
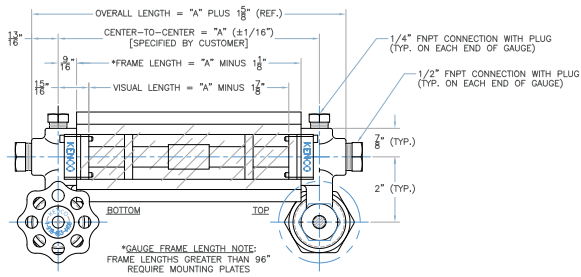

K9957 BULK TANK GAUGE

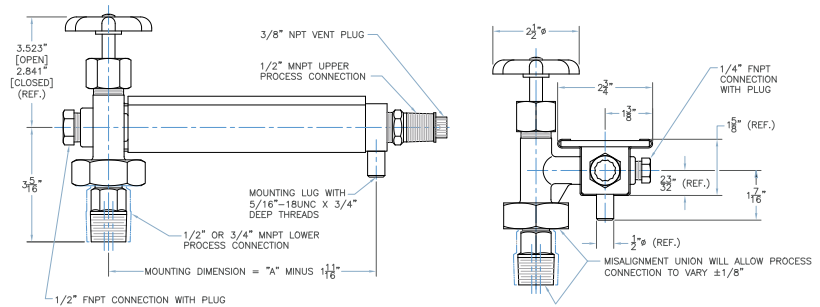
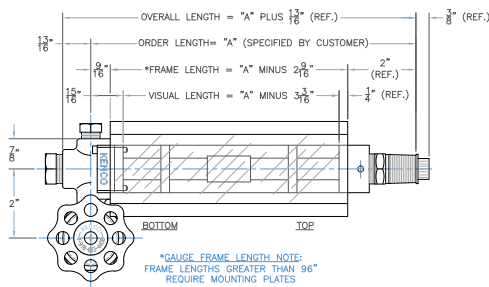

ORDERING SYSTEM

K9900 Series Bulk Tank Gauge

COMPANY: _____ CITY: _____ STATE: _____ ZIP: _____

REQUESTED BY: _____ PHONE: _____ FAX: _____

ADDRESS: _____ EMAIL: _____

Gauge Style

K99 = Gauge w/ Top & Bottom Integral Valves
 K9957 = Gauge w/ Integral Valve on Bottom and 1/2" MNPT x 3/8" FNPT Connection on Top

Process Connections

M50 = 1/2" MNPT
 M75 = 3/4" MNPT
 FL50 = 1/2" Flange
 FL75 = 3/4" Flange
 FL1.0 = 1" Flange
 FL1.5 = 1.5" Flange
 FL2.0 = 2" Flange

Center to Center Dimension (inches)

Material of Construction

C = Zinc Plated Carbon Steel
 A = Stainless Steel

Seal Material

V = Fluorocarbon
 A = Aflas
 B = Buna-N
 T = FEP Encapsulated Silicone
 E = Ethylene Propylene

Shield Options*

L = Clear Polycarbonate
 H = Height Scale
 RH = Rate Height Scale
 MH = Metric Height Scale
 MRH = Metric Rate Height Scale
 M = Expanded Metal Guard

Sight Tube Options**

GS = 5/8" O.D. Glass
 RL = 5/8" O.D. Redline Glass

Maximum Working Pressure (PSIG)

Maximum Operating Temperature (°F)

Steam

S = Steam Application
 NS = Non-Steam Application

* See page 12 for shield descriptions,

** Based on application data provided, Kenco will select the appropriate sight tube material, i.e. high pressure glass.