

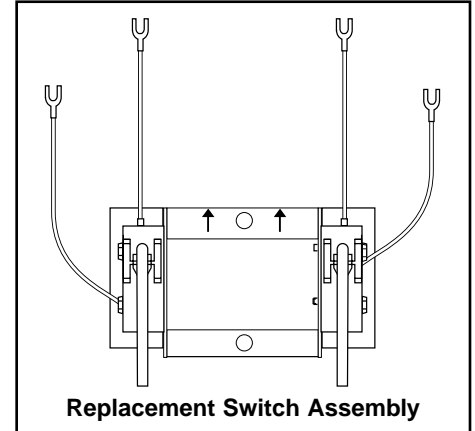

## Replacement Snap Switch Assembly SWA-42S

For Series 42S Low Water Cut-Off/  
Pump Controllers (All Models)



### **WARNING**

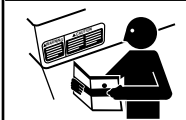

- Before using this product read and understand instructions.
- Save these instructions for future reference.



- All work must be performed by qualified personnel trained in the proper application, installation, and maintenance of plumbing, steam, and electrical equipment and/or systems in accordance with all applicable codes and ordinances.



- To prevent serious burns, the boiler must be cooled to 80°F (27°C) and the pressure must be 0 psi (0 bar) before servicing.



- To prevent electrical shock, turn off all sources of electrical power before servicing unit.
- This low water cut-off must be installed in series with all other limit and operating controls installed on the boiler. After servicing unit, check for proper operation of all of the limit and operating controls before leaving the site.



- To prevent a fire, do not use this low water cut-off to switch currents over 7.4A, 1/3 Hp at 120 VAC or 3.7A, 1/3 Hp at 240 VAC, unless a starter or relay is used in conjunction with it.

Failure to follow this warning could cause property damage, personal injury or death.

## Verify that you have the Correct Replacement Switch Assembly Model

**IMPORTANT:**

- Installation of an incorrect switch-assembly could cause damage to the boiler and/or boiler system.
- Modification of the switch assembly before or after installation could cause damage to the boiler and/or boiler system.
- Series 42S Replacement Snap Switch Assemblies are not interchangeable with Series 42 Mercury Switch Replacement Assemblies.
- Series 42S Replacement Snap Switch Assemblies are not interchangeable with Series 150S Snap Switch Replacement Assemblies, nor with Series 150 Mercury Switch Replacement Assemblies.

For Model	Repl. Switch Model No.	Description
42S 42S-A 42S-N 42S-HD	SWA-42S	Snap-action switch assembly

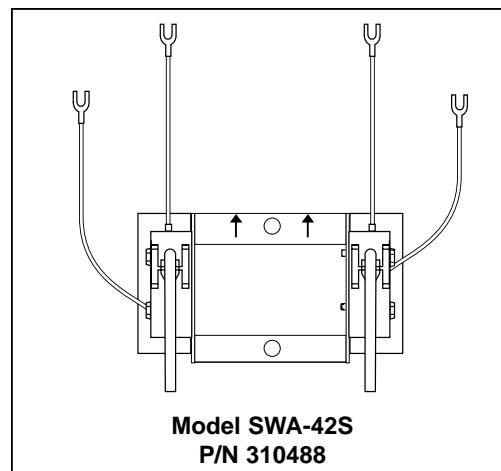

# OPERATION

**Maximum Pressure:** 50 psi (3.5 kg/cm<sup>2</sup>)

## Electrical Ratings

Voltage	Pump Circuit Rating (Amperes)		Pilot Duty
	Full Load	Locked Rotor	
120 VAC	7.4	44.4	345 VA at 120 or 240 VAC
240 VAC	3.7	22.2	

Motor Horsepower	
Voltage	Hp
120 VAC	1/3
240 VAC	1/3

## Settings and Differential Pressures

Values are  $\pm 1/8$ " (3.2mm).

**Series 42S**

Pressure	Setting	Approximate Distance Above Cast Line In. (mm)	Differential In. (mm)
50 psi (3.5 kg/cm <sup>2</sup> )	Pump Off	1 3/8 (35)	3/4 (19)
	Pump On	5/8 (16)	
	Burner On	7/8 (22)	7/8 (22)
	Burner Off	0 (0)	

1 3/8" (35mm)

PUMP OFF

BURNER OFF

NORMAL BOILER WATER LINE

BURNER CUT-OFF LEVEL AT CAST LINE

3/4" (19mm)

PUMP OFF

PUMP ON

NORMAL BOILER WATER LINE

BURNER CUT-OFF LEVEL AT CAST LINE

7/8" (22mm)

BURNER ON

BURNER OFF

NORMAL BOILER WATER LINE

BURNER CUT-OFF LEVEL AT CAST LINE

# INSTALLATION –

## SECTION 1 - Switch Bracket Replacement

### WARNING



- To prevent electrical shock, turn off the electrical power before making electrical connections.
- This low water cut-off must be installed in series with all other limit and operating controls installed on the boiler. After installation, check for proper operation of all of the limit and operating controls, before leaving the site.



Failure to follow this warning could cause electrical shock, an explosion and/or a fire, which could result in property damage, personal injury or death.

1. Turn the boiler off.

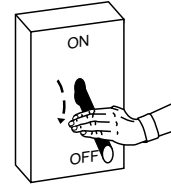

2. Allow the boiler to cool to 80°F (27°C) and release the boiler pressure to 0 psi (0 bar). Drain water in the boiler to a level which is below the float chamber (A).

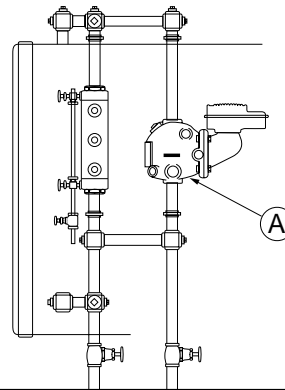

3. Remove the cover (B).

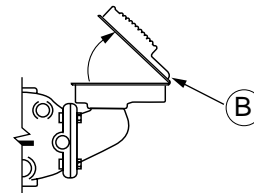

4. Mark and remove the pump switch and burner/alarm switch wires from terminal block.

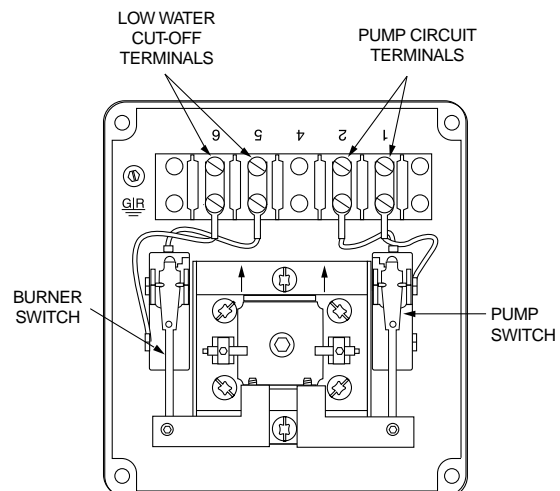

## Terminal Connection Reference Chart

Product	Switch	Terminal Connection				
		1	2	4	5	6
42S	2 Wire Pump	Blue	Orange			
	2 Wire Burner				White	Red

- 5a.** Locate the actuator assembly (A) and the two fillister head screws (B) which secure it to the bearing of the control.
- b.** Clean the inspection lacquer out of the screw slots in the two fillister head screws.
- c.** Remove the two screws holding the actuator assembly in place using a flat head screwdriver. Remove actuator assembly and place aside for reinstallation.

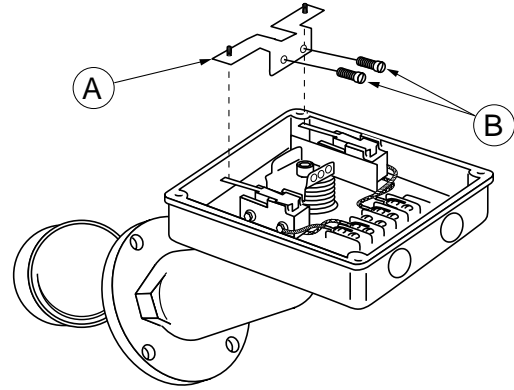

- 6.** Remove the two Torx® screws (C) holding the switch bracket assembly in place using a flat head screwdriver or a Torx® T30 wrench.

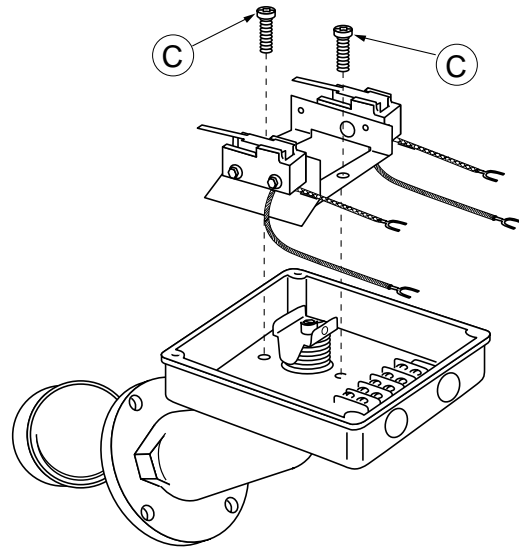

- 7.** Take the new switch bracket assembly out of the package and place the bagged supplies to one side while discarding the insert.

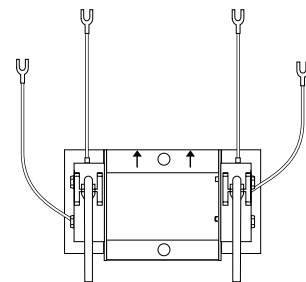

**8a.** Install the new switch bracket assembly into the junction box in the same orientation as the old switch bracket assembly (i.e. with arrows on the bracket pointing toward the terminal block).

**b.** Secure the new assembly with Torx® screws (C) and torque to 80 - 140 in. lb. (92 - 161 cm. kg.).

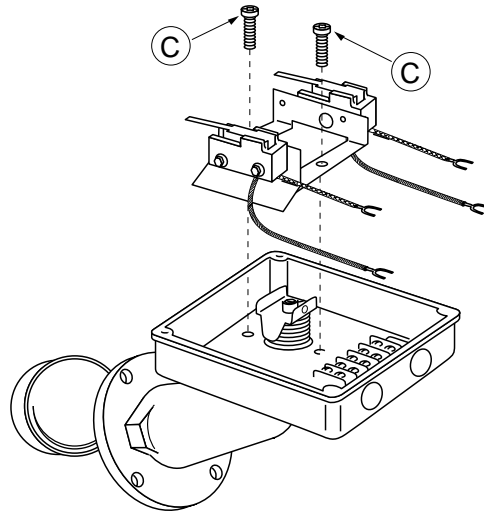

**9a.** Reaffix the actuator assembly using the two fillister head screws (B) and torque to 30 - 40 in. lb. (34.5 - 46 cm. kg.).

**b.** Apply a drop of the supplied adhesive to the threads of each fillister head screw.

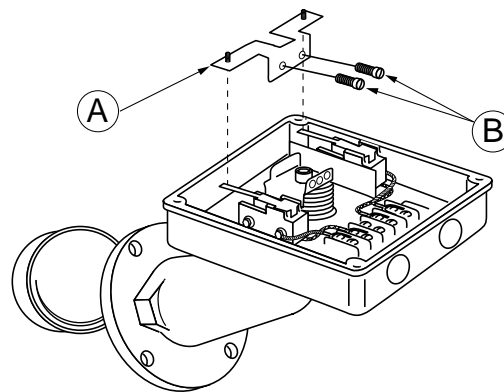

**10.** Reconnect the pump switch and burner/ alarm switch wires to terminal block as noted when disconnected and torque to 13 - 17 in. lb. ( 15 - 19.5 cm. kg.) (Refer to "Terminal Connection Chart" on page 5 if unsure of proper switch to terminal block wire connections).

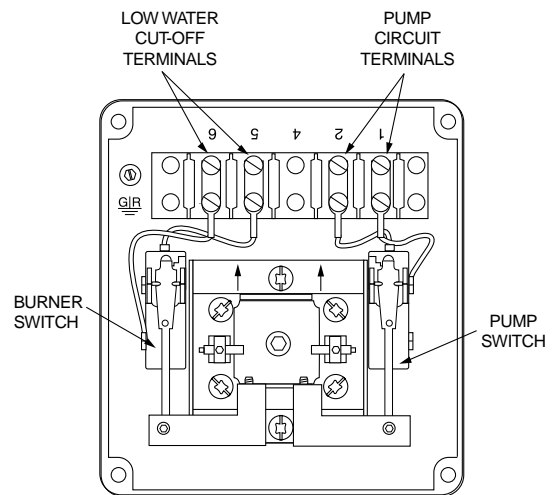

**11.** Reattach the cover (B).

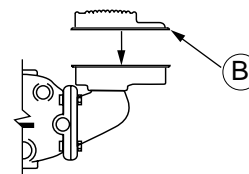

Proceed with normal operational checks of controls as described in Section 2; "Checking Switch Settings and Adjusting Switch Setpoints at Operating Pressure"; or Section 3; "Checking Switch Settings at "0" Pressure". The pump or burner switch operating points should be within +/- 1/4" of those specified for your control.

## SECTION 2 - Checking Switch Settings and Adjusting Switch Setpoints at Operating Pressure

**IMPORTANT:** All switches have fixed differentials. Adjustment of switches referred to in Section 2 and 3 are all based upon Pump Off and Burner Off setpoints. The Pump On and Burner On setpoints are not adjustable.

**We strongly recommend that you check the control at both the operating pressure and at 0 pressure.** All boilers start at 0 psi regardless of the operating pressure.

The operating points will spread out as the pressure goes up and shrink as the pressure goes down.

1. Cut out the "Switching Level Ruler" (page 11) along the indicated lines.

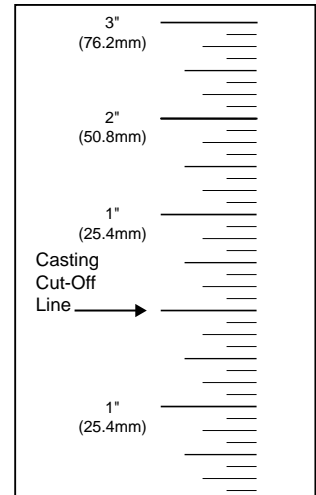

(Not to Scale. Template located on page 11).

- 2a. Hold the ruler against the side of the gauge glass in a position so the "Cast Line" mark is on the same level as the Cast Line on the float chamber of the control (D) (a carpenter's level should be used to insure the cast line on the float chamber is at the same level as the one on the ruler).

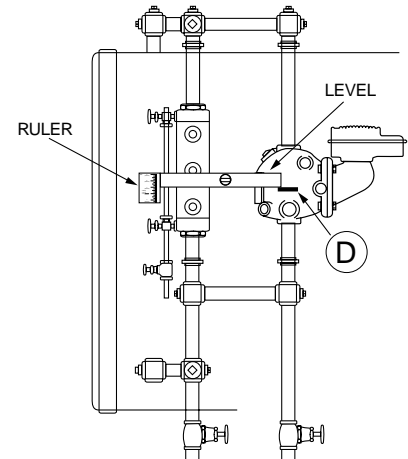

- b. Once the ruler is properly positioned, tape it to the gauge glass.

- 3a. Bring boiler up to normal operating pressure and turn the pump off.

- b. Remove the cover (B).

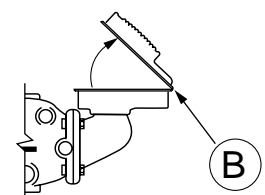

## 4 - Setting the Operating Points of the Burner Switch

- 4a.** Slowly bring the boiler water level down to the point at which the burner cuts off. If the burner does not shut off automatically by the time the water level reaches 3/8" (9.5mm) below the cast line on the unit body, shut the burner off manually.

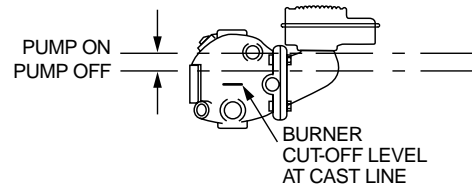

- 4b.** If the cut-off point does not match the one shown in chart for the control (page 3) as measured on the "Switch Level Ruler," using an awl, dig the inspection lacquer out of the socket in the set screw (E) above the burner switch in the actuator assembly.

- c.** Using an Allen wrench with a 5/64" hex, turn the screw 1/4 turn:
- clockwise when viewed from top (if the "Burner Off" point is too high)
  - counterclockwise when viewed from top (if the "Burner Off" point is too low)

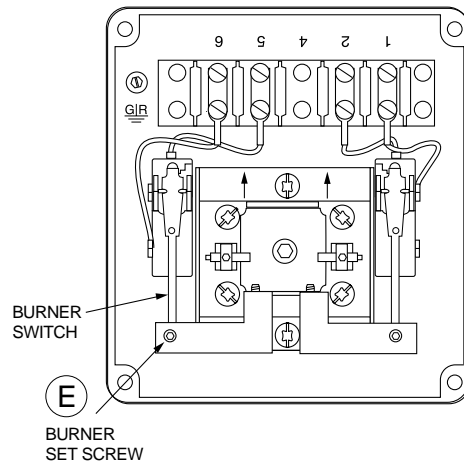

- 4d.** Turn the pump back on, allowing the boiler to fill with water.

- 4f.** Repeat steps **a.** through **d.** as necessary to match the Burner Off point specification for your model.

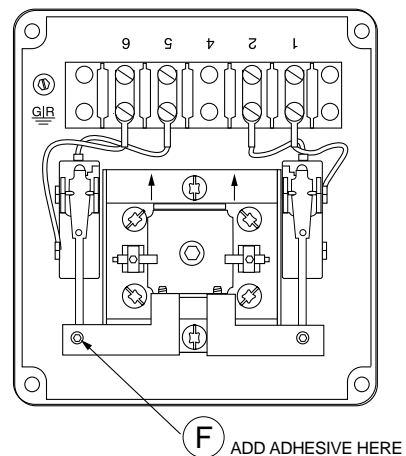

## 5 - Setting the Operating Points of the Pump Switch

- 5a.** Slowly drain the water in the boiler until the pump turns on. Allow pump to fill the boiler and observe the point on the ruler where the water level shuts off.

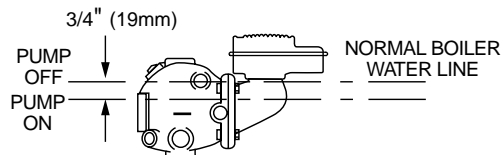

- 5b.** If the Pump Off point does not match the one shown in chart for the control (page 3) and as measured on the "Switching Level Ruler", dig the inspection lacquer out of the socket in the set screw (G) above the pump switch in the actuator assembly using an awl.

- c.** Using an Allen wrench with a 5/64" hex, turn the screw 1/4 turn:
- clockwise (if the "Pump Off" point is too high when viewed from top)
  - counterclockwise (if the "Pump Off" point is too low when viewed from top)

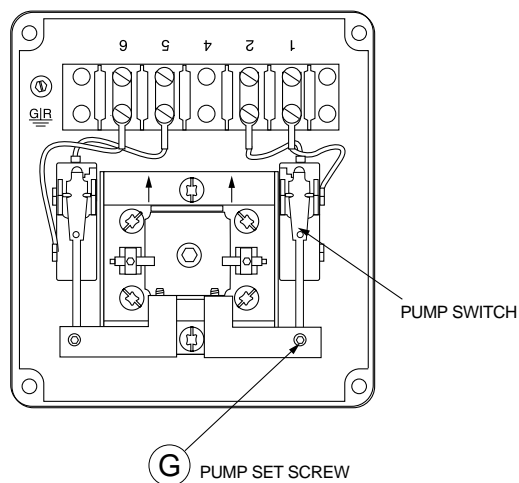

- 5d.** Slowly drain the water in the boiler until the pump turns on. Allow pump to fill the boiler and observe the point on the ruler where the water level shuts off.

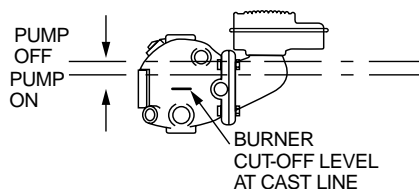

- 5e.** Repeat steps 5a. through d. as necessary to match the specified Pump Off point specification.

- f.** Apply one drop of adhesive (furnished) to the set screw threads (H) above the pump switch in the actuator assembly.

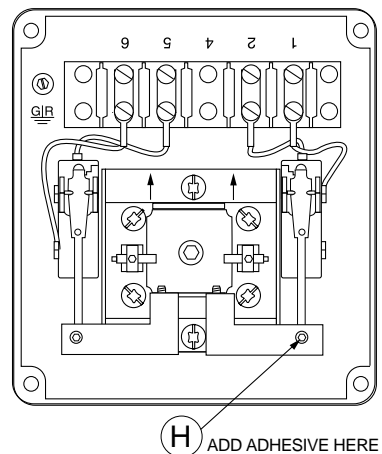

## SECTION 3 - Checking Switch Settings at 0 Pressure

**IMPORTANT:** All switches have fixed differentials. Adjustment of switches referred to in Sections 2 and 3 are all based upon Pump Off and Burner Off setpoints. The Pump On and Burner On setpoints are not adjustable.

1. Find the "Switching Level Ruler" on page 11, and cut it out along the indicated lines.

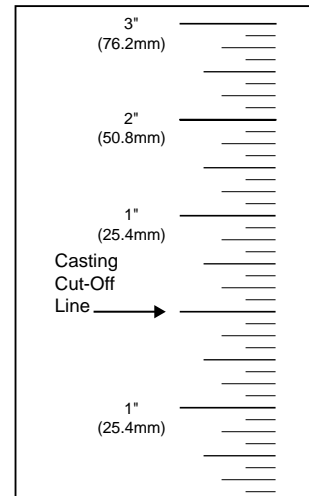

(Not to Scale. Template located on page 11).

2. Hold the ruler against the side of the gauge glass in a position so the Cast Line mark is on the same level as the cast line on the float chamber of the control (a carpenter's level should be used to insure the cast line on the float chamber is on the same plane as the one on the marker).
3. Once the marker is properly positioned, tape it to the gauge glass.

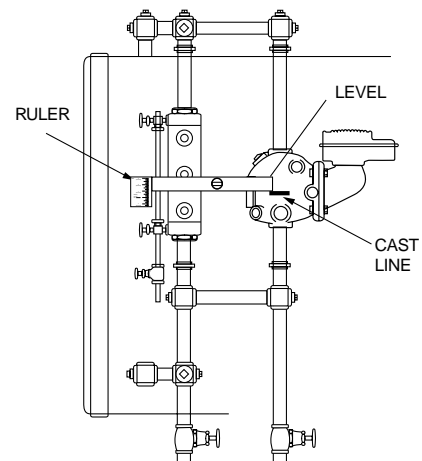

- 4a. Drain the water level in the boiler until the pump turns on. Note the level at which the pump turns on and then turns off. Verify that pump settings are acceptable.

- b. Turn the pump off.

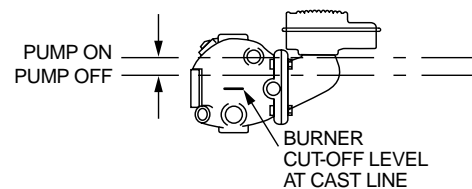

- 5a. Drain the water level in the boiler until the burner turns off. Observe the burner off point.

- b. Turn the pump back on and observe the Burner On point as the boiler fills with water. In the case of manual reset models, try resetting the burner switch as close as possible to the Burner On point as shown in chart for the control and as measured on the switch level ruler. Verify that burner settings are acceptable.

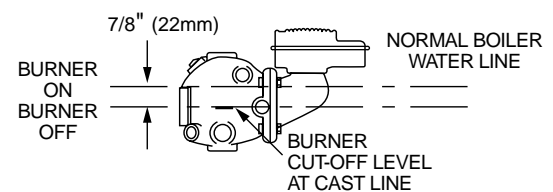

6. Reattach the cover (B).

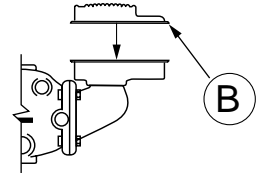

7. Turn the boiler on.

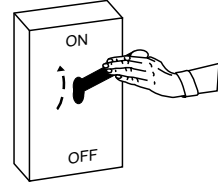

**TOP**

3"  
(76.2mm)

2"  
(50.8mm)

1"  
(25.4mm)

Casting  
Cut-Off  
Line →

1"  
(25.4mm)

← **CUT HERE**

### Switch Level Ruler

Cut to actual size and attach to piece of cardboard.