

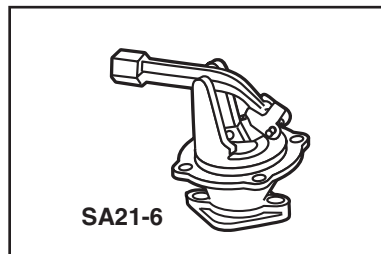

# Model 21 and 221 Mechanical Water Feeders And Replacement Valve Assembly SA21-6

**Applications:**  
For receiver tanks in industrial or commercial applications.

**Maximum water supply pressure: 150 PSIG (10.55 kg/cm<sup>2</sup>)**  
**Maximum vessel pressure: 35 PSIG (2.46 kg/cm<sup>2</sup>)**  
**Maximum fluid temperature: 120°F (49°C)**

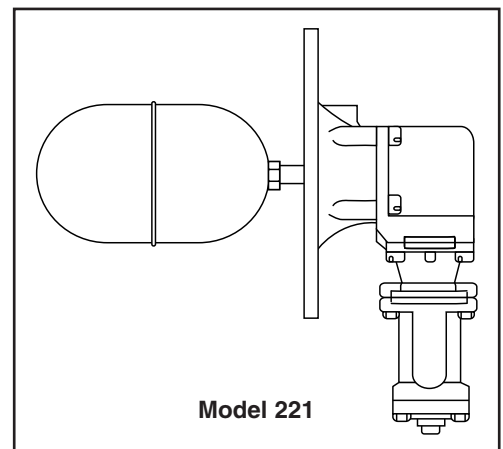
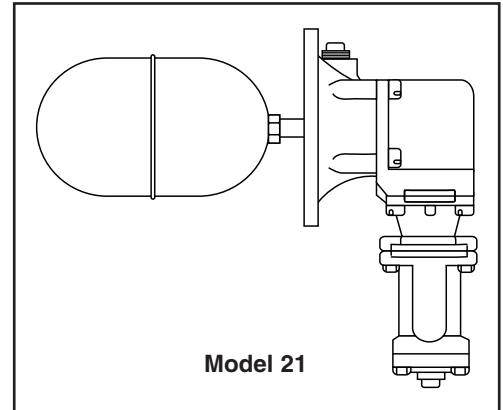

## **WARNING**

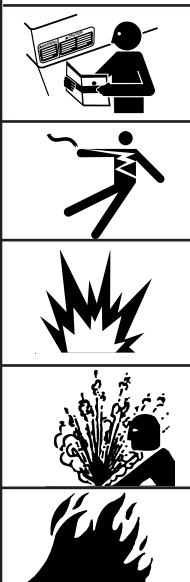

- Before using this product read and understand instructions.
- Save these instructions for future reference.
- All work must be performed by qualified personnel trained in the proper application, installation, and maintenance of plumbing, steam, and electrical equipment and/or systems in accordance with all applicable codes and ordinances.
- Drain water level down below feeder and let cool to 80° (27°C) before servicing.
- If tank or receiver is pressurized relieve pressure to 0 psi (0 Bar) before servicing.
- To prevent water damage check to make sure there is adequate floor drainage capacity. Check all components in the system to insure they will not leak in the event of an overfeed condition.

Failure to follow this warning could cause property damage, personal injury or death.

## OPERATION

The Series 21 make-up water feeder provides dependable, float-operated automatic water filling service to tanks used as condensate receivers in boiler systems. The valve components are of brass, an elastomer sealing disc and stainless steel materials, and a 4-3/4" diameter copper float providing

closure against supply pressure up to 150 PSI. An integral strainer and housing with removable drainage plug precede the valve for regular servicing. The control is a direct-feeding unit (feeds through the flange connection) available in two flange sizes.

## TYPICAL INSTALLATIONS

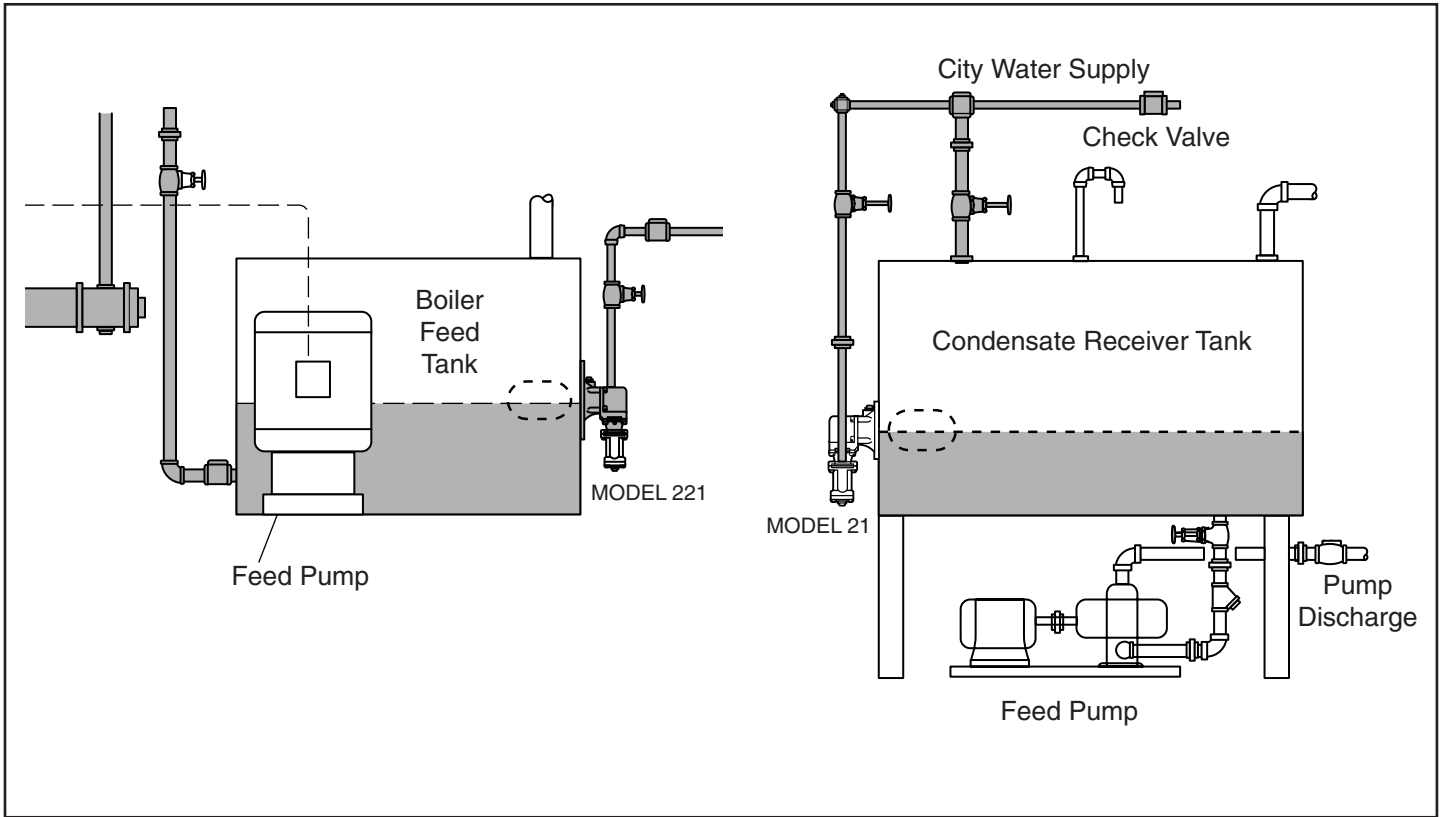

## Capacities

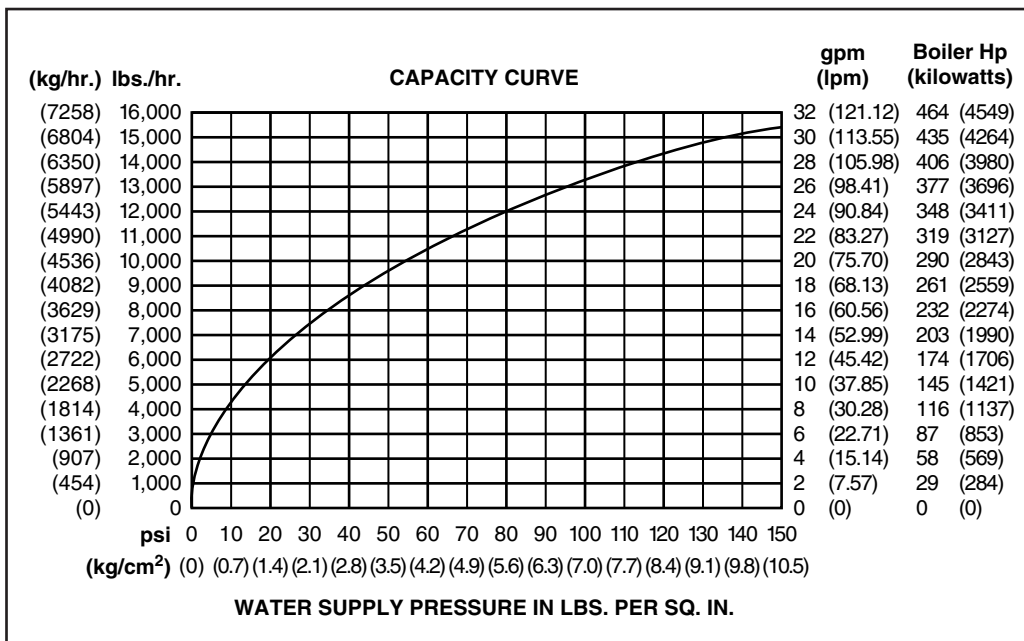

# INSTALLATION

## TOOLS NEEDED:

One (1) adjustable wrench, socket wrenches, two (2) pipe wrenches, pipe dope, assorted fittings and lengths of 3/4" pipe.

## STEP 1 - Preparation

This Water Feeder mounts directly on the tank or vessel. The tank or vessel is to be manufactured with a mating flange (A) and opening large enough for the float. The flange can be either welded flush on the side or head and have pre-tapped mounting holes (preferred), or a necked or nozzle flange with plain mounting holes. Either must have a 1-3/8" maximum distance from the outer flange face to the interior wall surface to allow the float to fully drop to get maximum valve capacity.

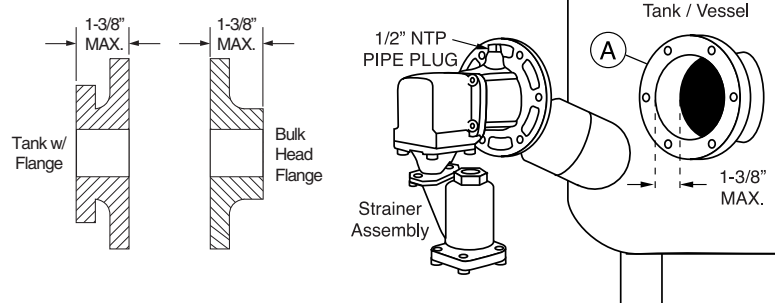

## Flange Dimension Details

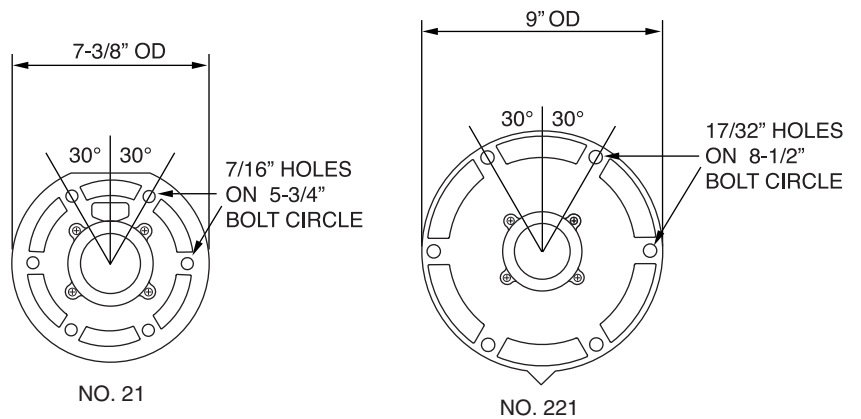

## STEP 2 - Install the Piping

The feeder is usually mounted one-third (1/3) of the way up from the bottom of the tank. This provides two-thirds (2/3) of the tank for return condensate.

Follow the diagram for piping the feeder to the tank and water supply. Remember to leave room for the servicing the water feeder. At all right angle turns in the equalizing piping, crosses should be used to facilitate inspection and cleaning.

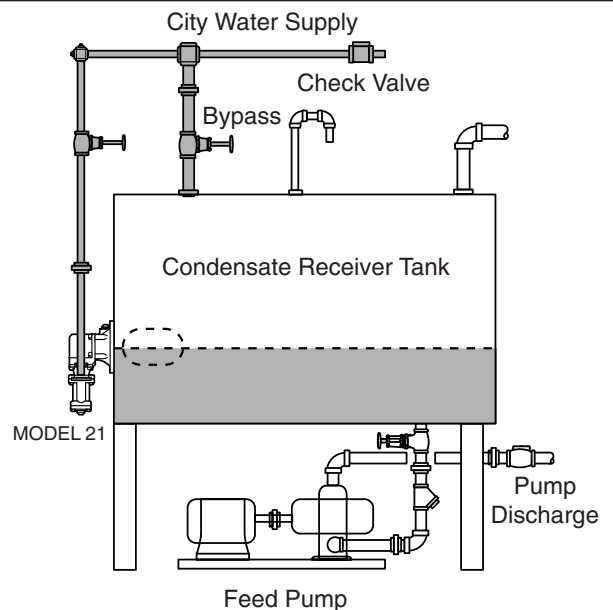

**INSTALLATION (cont.)**
**21 Series - Replacement Valve Assembly (SA21-6)**

**a. Remove Feeder from Tank.** Turn off the water supply and drain the tank below the level of the feeder flange. If fluid is heated, allow system to cool to 80°F (27°C) before disassembly. Disconnect the piping above the strainer assembly. Remove the six (6) mounting bolts and lift off the feeder from the tank.

**b. Remove Valve Assembly.** Remove float and rod from the float arm of the valve linkage. Unscrew the two (2) bolts from the strainer body at the bottom of the valve assembly. Unscrew the four (4) bolts from the valve body at the bottom of the valve housing bracket. Pull the valve assembly from the housing in an arcing movement to clear the float arm from the interior.

**c. Reassemble with new Valve Assembly.** Position the new valve assembly with new gasket, float arm first, into the housing. Hand secure the four (4) bolts and tighten to 16 ft/lbs. Replace the strainer body and new gasket using the two (2) bolts. Tighten to 16 ft/lbs. Reattach the float and rod onto the float arm and hand tighten.

**d. Replace Feeder on Tank.** Replace the assembly and new gasket onto the tank flange. Tighten the six (6) bolts to 16 ft/lbs. Reconnect the piping and restore water supply. Check for proper closing level and leakage before leaving the jobsite.

**Note:** Use new gaskets; make sure all gasket surfaces are clean.

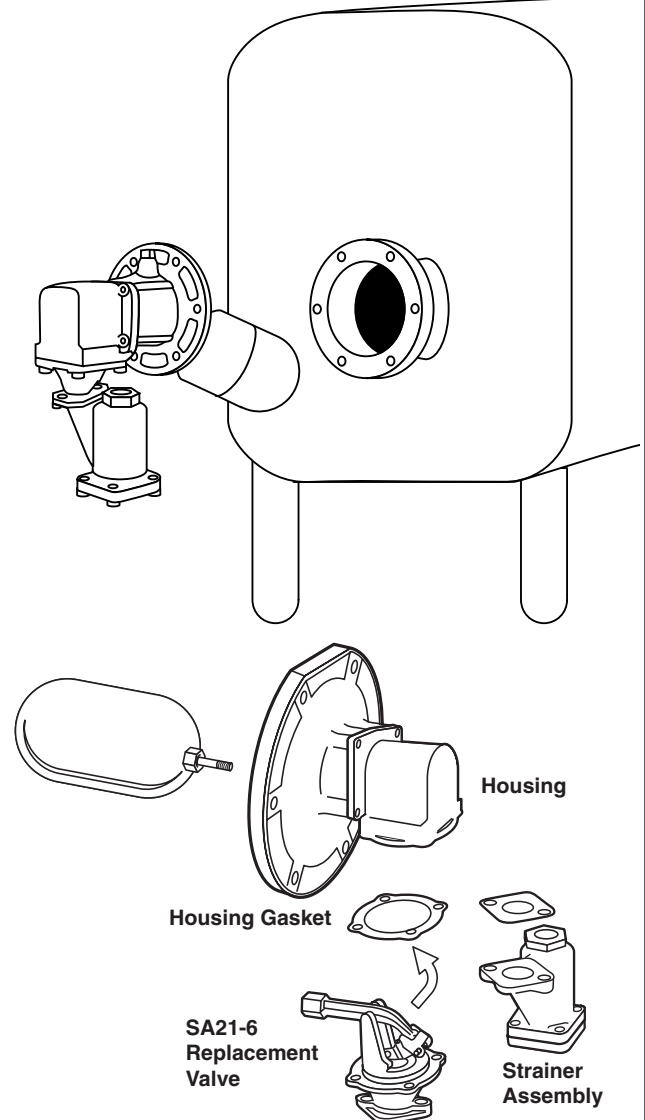
**MAINTENANCE:**

- **Blow down tank weekly during heating season.** Blow down may have to be more frequent depending on local water conditions and the amount of make-up water.
- **Clean strainer at least twice during heating season.** Cleaning may have to be more frequent depending on local water conditions and the amount of make-up water.
- **Replace control every 15 years.**