

# KENCO ENGINEERING COMPANY

P.O. BOX 470426, TULSA, OK 74147-0426 ♦ PHONE: (918) 663-4406 FAX: (918) 663-4480  
<http://www.kenco-eng.com> e-mail: [info@kenco-eng.com](mailto:info@kenco-eng.com)

## K99FL INSTALLATION / OPERATING INSTRUCTIONS

### Installation Instructions-(See Exploded Drawing On Page 2 For Part Listing)

Only Qualified Personnel Who Are Familiar With Gauge Glass Valves And Their Operation Should Undertake Installation Of This Product. Failure To Properly Install Could Result In Serious Personal Injury And Property Damage.

**Note: For Steam-Water Applications, Use Needle Nose Pliers To Remove Retainer Springs(Item 22) And Discard Ball Checks(Item 21)On Both Top And Bottom Valve Assemblies.**

1. Prior To Actual Installation, Turn Handwheel On Upper And Lower Valve On Gauge Clockwise Until Stem Closes Against Seat.
2. Remove Union Nut (Item 25). Align The Flanged Connections On Each End To Flanged Tank Connections. Using A Torque Wrench, Tighten The Flange Bolts In A Regular Pattern To Avoid Uneven Loads On The Gauge. It Is Necessary To Torque Individual Flange Bolts In Small Amounts, Moving To The Next Flange Bolt After Each Increment Of Torque.
3. Inspect O-Ring Seal (Item 23) On Face Of Upper & Lower Valve Body To Make Sure It Is In Groove And Installed With Lubricant. Kenco Factory Installs O-Rings Using A Silicone Based Seal Lubricant.
4. Re-Attach Union Nut To Gauge. Tighten Union Nuts Until They Bottom Out On Valve Assembly.
5. Re-Check Vessel Connections As Well As 1/2" FNPT Vent/Drain Connections On Each End Of Gauge To Ensure That They Are Pressure Tight.
6. Turn Valve Handwheels Counterclockwise Very Slowly To Avoid Excessive Thermal Shock And Mechanical Stress On Tubular Gauge Glass Sight Tube Contained Inside Gauge Frame.
7. Allow Gauge Temperature And Pressure To Slowly Equalize With Vessel.

**Note: Failure To Slowly Bring Gauge Into Service Will Cause Rapid Pressurization Of Sight Tube Which Could Result In Serious Personal Injury And Property Damage.**

8. Inspect Gauge To Insure That There Are No Leaks Prior To Proceeding With Installation.
9. Open Valves Completely After Temperature And Pressure Have Equalized To Permit Ball Checks In Valve Bodies To Properly Seat In The Event Of Possible Glass Breakage. (Note: In Some Circumstances Where Liquid Being Gauged Tends To Surge In A Rapid Manner, Ball Checks Can Seat And Give A False Level Reading).

### Maintenance Instructions

1. During System Shutdown, Gauge Valves Are To Be Left Open To Allow Gauge To Lose Pressure And Cool To Ambient Temperature With Vessel.
2. Should Gauge Need Maintenance While Vessel Is Still In Service, Valves On Each End Of Gauge Are To Be Closed Completely To Allow Gauge To Cool To Ambient Temperature If Necessary. Liquid Can Then Be Carefully Drained By Using 1/2" NPT Connection Port On Lower End Of Gauge.

**Note: Do Not Proceed With Any Maintenance Unless Gauge Has Been Relieved Of All Pressure Or Vacuum And Has Been Allowed To Reach Ambient Temperature. Gauge Should Also Be Flushed Out To Remove Any Hazardous Liquids Before Handling If Possible.**

3. Cleaning Inside Of Sight Tube Can Be Done Without Removal Of Tube Itself. This Can Be Accomplished By Using A Tube Brush With Access Through 1/2" FNPT Vent/Drain Connection Ports On Each End Of Gauge.
4. Removal Of Sight Tube Contained Inside Gauge Frame Is As Follows:
  - A. Remove Existing Clear Polycarbonate Or Expanded Metal Shield By Bending Crimped Portion Of Gauge Frame On Each End Away From Shield So It Can Easily Slide Out.
  - B. Remove (2) Hex Socket Head Cap Screws In Blocks On Each End Of Gauge Holding 1-1/4" Square X 1/4" Thick O-Ring Compression Plates In Place.
  - C. Push Sight Tube Up Into Upper Block As Far As Is Required To Enable Lower End Of Sight Tube To Swing Out From Frame Inside Gauge Frame.  
**Note: On Very Short Gauges, It May Be Necessary To Remove Sight Tube Through 1/2" FNPT Vent Port On Upper End Of Gauge.**
  - D. Carefully Lower Sight Tube Out Of Block In Upper End Of Gauge Frame.

**Note: If Sight Tube Has A Splicer, Extra Care Should Be Taken So Sight Tube Assembly Does Not Disassemble.**

E. Remove O-Ring Compression Plates And Seals From Sight Tube.

5. Installation Of Sight Tube Is As Follows:

A. Insert Sight Tube Into Splicer If One Exists. If A Teflon Shrink-Tube Type Splicer Exists, It Will Be Necessary To Place Teflon O-Ring Cushion Between Adjoining Sight Tubes And Heat-Shrink Teflon Splicer In Place.

B. Slide 1-1/4" Square X 1/4" Thick O-Ring Compression Plate Onto Each End Of Sight Tube.

C. Slide O-Ring Seal Onto Each End Of Sight Tube.

D. Push End Of Sight Tube Into Hole In Block Inside Frame On Upper End Of Gauge As Far As Is Required To Enable Lower End Of Sight Tube To Swing Over And Into Hole In Block Inside Frame On Lower End Of Gauge.

**Note: On Very Short Gauges, It May Be Necessary To Install Sight Tube Through 1/2" FNPT Vent Port On Upper End Of Gauge.**

E. Install Hex Socket Head Cap Screws Into Blocks On Each End Of Gauge And Thread Into Holes In 1-1/4" Square X 1/4" Thick O-Ring Compression Plates And Tighten Securely.

6. Integral Valve Body Contained On Each End Of Gauge To Be Assembled And Disassembled As Illustrated In Exploded View Below (Note: When Reassembling Valves Bodies, We Recommend Using A Lubricating Compound On Threads To Protect Against Corrosion, Seizure, Galling, Rust, Carbon Fusion, Etc.)

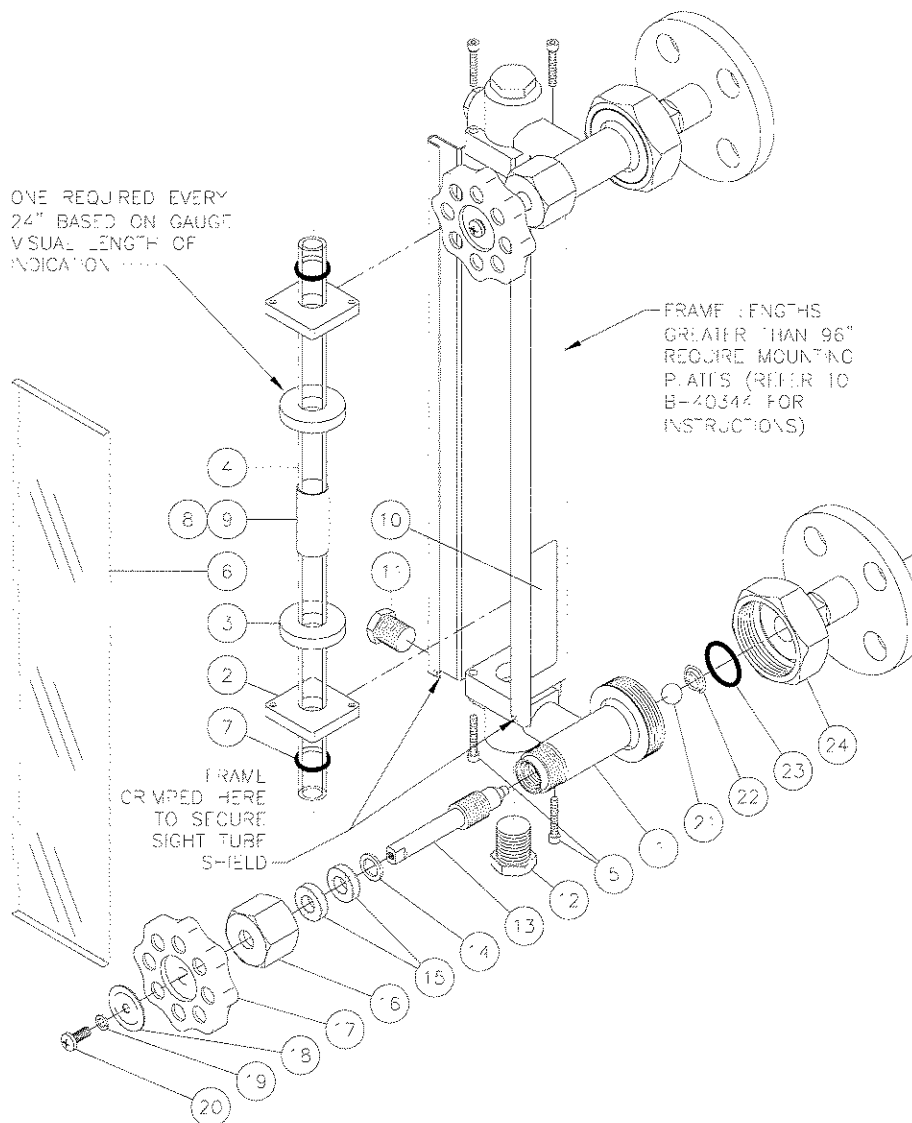

# KENCO ENGINEERING COMPANY

P.O. BOX 470426 TULSA, OK 74147-0426  
PHONE: (918) 663-4406 FAX: (918) 663-4480  
www.kenco-eng.com e-mail: info@kenco-eng.com

## REPAIR KITS FOR MODEL K9900

### GAUGE GLASS REPAIR KIT

K9900-RK-(CENTERLINE)-(O-RING SEAL MATERIAL)\*  
GLASS LENGTH = CENTER/CENTER - 3/4"

\*IF YOU REQUIRE SPECIAL GLASS [I.E. REDLINE (-RL), STANDARD GLASS WITH REDLINE TAPE (-GSRL), HIGH PRESSURE (-HP), HIGH PRESSURE GLASS WITH REDLINE TAPE (-HPRL), HEAVY WALL (-HW), HEAVY WALL GLASS WITH REDLINE TAPE (-HWRL)], THE CORRESPONDING SUFFIX FOR THE REQUIRED GLASS TYPE MUST BE ADDED TO THE END OF THE GAUGE GLASS REPAIR KIT PART NUMBER. (EXAMPLE K9900-RK-24-T-HP)

#### CONSISTS OF:

- (1) 5/8" O.D. GAUGE GLASS
- (2) O-RING SEALS

#### O-RING SEAL OPTIONS

V=FLUOROCARBON  
A=AFLAS  
B=BUNA-N

E=ETHYLENE PROPYLENE  
T=PTFE ENCAPSULATED SILICONE

### VALVE STEM PACKING REPAIR KIT

K9900-VK

#### CONSISTS OF:

- (2) VALVE STEMS
- (2) RETAINER WASHER FOR VALVE STEM PACKINGS
- (4) VALVE STEM PACKINGS

### REPLACEMENT SHIELD REPAIR KIT

3725-SI-(SHIELD STYLE)-(LENGTH OF SHIELD)

SHIELD LENGTH = GAUGE CENTER TO CENTER - 1 3/8"

#### STANDARD SHIELD STYLES:

L = CLEAR POLYCARBONATE  
L-UV = CLEAR UV FILTERED ACRYLIC  
M = EXPANDED METAL  
RH = RATE / HEIGHT SCALE

MRH = METRIC RATE / HEIGHT SCALE  
H = HEIGHT SCALE  
MH = METRIC HEIGHT SCALE

\* TO ENSURE CALIBRATION ACCURACY, RATE SCALES(-RH, -MRH) SHOULD ONLY BE SELECTED WITH THE -GS AND -GSRL GLASS OPTIONS

**O-RING REPAIR KIT**

**(REPLACES ALL O-RINGS)**

**K9900-OK-(O-RING SEAL MATERIAL)**

**CONSISTS OF:**

**(2) GAUGE GLASS SIGHT TUBE O-RING SEALS**

**(2) MISALIGNMENT UNION O-RING SEALS**

**(4) TEFLON VALVE STEM PACKINGS**