

KUNKLE

Features

- O-ring seats available for exceptional leak-free performance, reduced maintenance cost, multiple cycles with tight shutoff, improved seating integrity.
- Wide hex on valve nozzle provides wrenching service clearance for easy installation.
- Dual control rings offer easy adjustability for precise opening with minimum preopen or simmer and exact blowdown control.
- Pivot between disc and spring corrects misalignment and compensates for spring side thrust.
- Grooved piston model disc reduces sliding area and friction.
- Each Kunkle valve is tested and inspected for pressure setting and leakage.

Model Descriptions

Model 6010: Side outlet. Full nozzle design with bronze/brass trim. Available with O-ring seats. For exceptional leak-free performance.

Model 6021: Same as model 6010 with Teflon® (PFA) disc insert. For exceptional leak-free performance (use on steam only).

Model 6030: Same as model 6010 except Stainless Steel (SS) trim (nozzle and disc). Available with O-ring seats for exceptional leak-free performance.

Model 6182: Top outlet. Full nozzle design with bronze/brass trim. O-ring seat available for exceptional leak-free performance.

Model 6121: Same as model 6182 with Teflon® (PFA) disc insert. For exceptional non-leak performance (use on steam only).

Model 6130: Same as model 6182 except SS trim (nozzle and disc). O-ring seat available for exceptional leak-free performance.

Model 6186: Top outlet. Full nozzle design with bronze/brass trim. 150 psig [10.3 barg] maximum set pressure. Replaces Model 86 (original equipment only).

Model 6283: Over-sized side outlet. Full nozzle design bronze/brass trim.

Model 6221: Same as model 6283 with Teflon® (PFA) disc insert. For exceptional leak-free performance (use on steam only).

Model 6230: Same as model 6283 except SS trim (nozzle and disc).

Model 6933: Same as model 6010 except certified for ASME code Section IV. Low pressure steam heating boilers set at 15 psig [1.0 barg] only.

Model 6934: Same as model 6021 except certified for ASME code Section IV. Low pressure steam heating boilers set at 15 psig

**ASME Section I and VIII, Steam, “V” and “UV,”
ASME Section VIII, Air/Gas “UV” National Board Certified.
Models 6933, 6934, and 6935 are ASME Section IV, “Steam”
“HV” National Board Certified.
PED Certified for Non-Hazardous Gas.**



[1.0 barg] only.

Model 6935: Same as model 6030 except certified for ASME code Section IV. Low pressure steam heating boilers set at 15 psig [1.0 barg] only.

Applications

- Steam Boilers and Generators.
- Air/Gas Compressors - reciprocating or rotary - portable or stationary, intercoolers and aftercoolers.
- Pressure Vessels - containing steam, air or non-hazardous gas. Including tanks, receivers, sterilizers and autoclaves.
- Pressure Reducing Stations - protection of the discharge or low pressure side of system.

Pressure and Temperature Limits

**Models 6010, 6021, 6182, 6283, 6221
Steam Service**

3 to 250 psig [0.2 to 17.2 barg]
-60° to 406°F [-51° to 208°C]

Air/Gas Service

3 to 300 psig [0.2 to 20.7 barg]
-60° to 406°F [-51° to 208°C]

Models 6030, 6130, 6230

Steam and Air/Gas Service
3 to 300 psig [0.2 to 20.7 barg]
-60° to 425°F [-51° to 218°C]

Note

1. Resilient seats determine temperature range (see page 11).

Parts and Materials

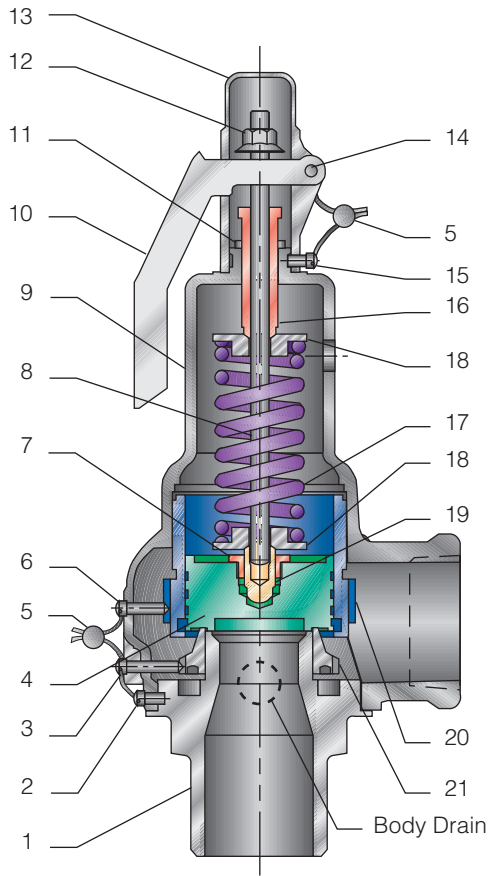

**Models 6010, 6030, 6283,
6230, 6933, 6935**

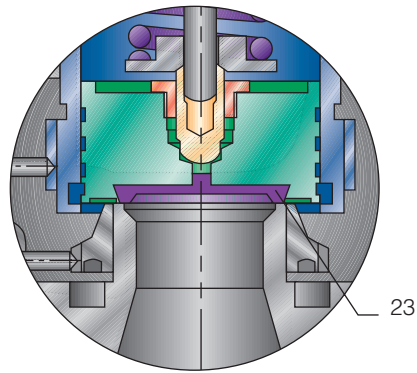

**Models 6121, 6221, 6934
Teflon® Seat Configuration**

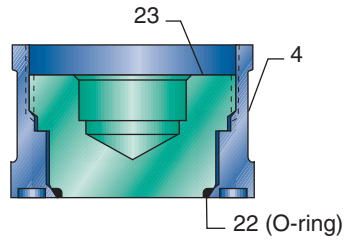

**Models 6010, 6030, 6283,
6230, 6933, 6935
Optional Soft Seat**

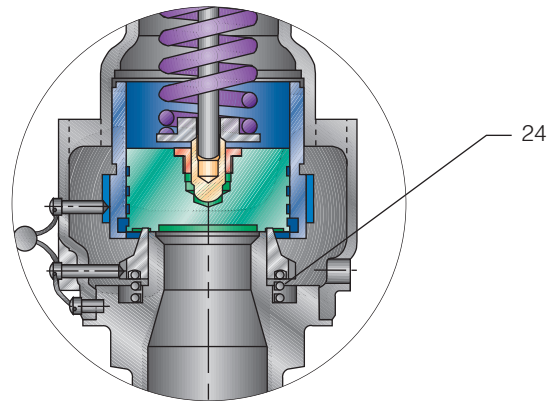

**Models 6182, 6121, 6130, 6186
Top Outlet Configuration**

Parts and Materials

No.	Part Name	Materials
1	Nozzle	BRS B283-C48500 or BRZ SB62 ³
2	Body Set Screw	SS 18-8
3	Warn Ring Set Screw	SS 18-8
4	Disc	B21 C48500 ⁴
5	Wire and Seal	SS Wire and Lead Seal
6	Guide Set Screw	SS 18-8
7	Retainer Nut ²	Brass B16
8	Stem	SS, A582 TY416
9	Body	BRZ B584-C84400
10	Lever	STL A109 or JIS SPCC Equivalent/ZN Plated Yellow
11	Jam Nut	Brass B16
12	Lift Nut	STL A108-1018/ZN Plated
13	Cap	Aluminum, Anodized
14	Lever Pin	STL A108-12L14
15	Cap Set Screw	SS 18-8
16	Compression Screw	BRS B16
17	Spring	ASTM A-313 TY 631
18	Spring Step	BRS B16
19	Stem Retainer	BRS B16
20	Guide	BRS B16 for D and E Orifice BRZ B584-C84400 for F through J Orifice
21	Warn Ring ⁷	BRS B16
22	Seat	Note 1
23	Seat Retainer	BRS B16 ⁵
24	Warn Ring Spring ⁶	STL

Notes

- Models 6021, 6121, 6221 and 6934 Teflon®, optional O-ring seat available for all others except models 6933 and 6935.
- Section IV only.
- Models 6030, 6130, 6230 and 6935 are SS SA351-CF8.
- Models 6030, 6130, 6230 and 6935 are SS SA479-304 (D through H Orifice) or SS SA479-316 (J Orifice).
- Models 6030, 6130 and 6230 are SS SA479-304.
- Variation 02 (vibration dampening) only.
- Soft seat "D" and "E" orifice require special warn ring (notch on O.D. of fins).

Kunkle Safety and Relief Products

Series 6000

Specifications

Model Number ¹	Orifice	Connections				Valve Dimensions			Approximate Weight				
		ANSI Standard				in [mm]			lb	[kg]			
		Inlet	Outlet	A	B	C							
in	[mm]	in	[mm]										
60**DC#	D	1/2	[12.7]	3/4	[19.0]	2 7/8	[54]	1 5/8	[41]	6 1/2	[165]	1 1/2	[0.7]
60**DD# ²	D	3/4	[19.0]	3/4	[19.0]	2 1/8	[54]	1 5/8	[41]	6 1/2	[165]	1 3/4	[0.8]
61**DC#	D	1/2	[12.7]	—	—	—	—	—	—	6 1/2	[165]	1 1/4	[0.6]
60**ED#	E	3/4	[19.0]	1	[25.4]	2 3/8	[60]	1 3/4	[44]	7 1/2	[191]	2 1/2	[1.1]
60**EE# ²	E	1	[25.4]	1	[25.4]	2 1/2 ⁴	[64]	1 3/4	[44]	7 5/8 ⁵	[194]	2 3/4	[1.2]
61**ED#	E	3/4	[19.0]	—	—	—	—	—	—	7 1/2	[191]	2 1/4	[1.0]
62**ED#	E	3/4	[19.0]	1 1/4	[31.75]	2 7/8	[73]	1 3/4	[44]	7 1/2	[191]	2 3/4	[1.2]
60**FE#	F	1	[25.4]	1 1/4	[31.8]	2 5/8	[67]	2	[51]	8 1/2	[216]	3 1/2	[1.6]
60**FF# ²	F	1 1/4	[31.8]	1 1/4	[31.8]	2 7/8	[73]	2	[51]	8 3/4	[222]	3 3/4	[1.7]
61**FE#	F	1	[25.4]	—	—	—	—	—	—	8 1/2	[222]	3 1/4	[1.5]
62**FE#	F	1	[25.4]	1 1/2	[38.0]	2 7/8	[73]	2	[51]	8 1/2	[222]	3 3/4	[1.7]
60**GF#	G	1 1/4	[31.8]	1 1/2	[38.0]	3 1/8	[79]	2 3/8	[60]	9 5/8	[244]	5 1/2	[2.5]
60**GG# ²	G	1 1/2	[38.0]	1 1/2	[38.0]	3 3/8	[86]	2 3/8	[60]	10	[254]	5 3/4	[2.6]
61**GF#	G	1 1/4	[31.8]	—	—	—	—	—	—	9 5/8	[244]	5	[2.3]
62**GF#	G	1 1/4	[31.8]	2	[51.0]	3 3/8	[86]	2 1/4	[57]	9 5/8	[244]	5 3/4	[2.6]
60**HG#	H	1 1/2	[38.0]	2	[51.0]	3 5/8	[92]	2 3/4	[70]	10 5/8	[270]	7 3/4	[3.5]
60**HH# ²	H	2	[51.0]	2	[51.0]	4 1/8	[105]	2 3/4	[70]	11 1/8	[283]	8	[3.6]
61**HG#	H	1 1/2	[38.0]	—	—	—	—	—	—	10 5/8	[270]	7 1/4	[3.3]
62**HG#	H	1 1/2	[38.0]	2 1/2	[64.0]	3 7/8	[98]	3	[76]	10 5/8	[270]	8	[3.6]
60**JH#	J	2	[51.0]	2 1/2	[64.0]	4 1/4	[108]	3 3/8	[86]	13 5/8	[346]	15 1/2	[7.0]
60**JJ# ²	J	2 1/2	[64.0]	2 1/2	[64.0]	4 1/2	[114]	3 3/8	[86]	14	[356]	15 3/4	[7.2]
61**JH#	J	2	[51.0]	—	—	—	—	—	—	13 5/8	[346]	15	[6.8]
62**JH#	J	2	[51.0]	3	[76.0]	4 5/8	[117]	3 3/8	[86]	13 5/8	[345]	15 1/2	[7.0]

Dimensions are for reference only.

Notes

1. Replace asterisks with desired model number. Replace # with desired seat material.
2. Model 6030 and 6935 available only 1/2 x 3/4" [12.7 x 19 mm], 3/4 x 1" [19 x 25.4 mm], 1 x 1 1/4" [25.4 x 31.8 mm], 1 1/4 x 1 1/2" [31.8 x 38 mm], 1 1/2 x 2" [38 x 51 mm] and 2 x 2 1/2" [51 x 64 mm].
3. Models 6933, 6934 and 6935 have same dimensions as model 6010.
4. 2 1/4" for BSP [57].
5. 7 3/8" for BSP [192.5].

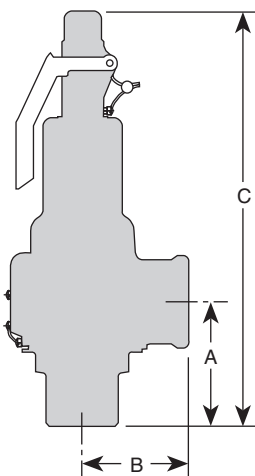

Capacities

Non-code¹ and ASME Section VIII Air (U.S., SCFM)

Flow Coefficient = 0.878

Set Pressure (psig)	Orifice Area, in ²					
	D (0.121)	E (0.216)	F (0.338)	G (0.554)	H (0.863)	J (1.414)
3	28	50	78	127	198	325
4	32	57	89	146	228	374
6	39	70	109	178	278	456
8	45	80	125	205	319	523
10	50	89	139	228	355	582
15	64	114	178	292	454	744
20	73	131	205	336	524	858
25	83	148	232	381	593	972
30	93	166	259	425	663	1086
35	104	185	289	474	739	1211
40	114	204	319	523	815	1336
45	125	223	349	572	892	1461
50	136	242	379	621	968	1586
55	146	261	409	671	1045	1711
60	157	281	439	720	1121	1837
65	168	300	469	769	1197	1962
70	179	319	499	818	1274	2087
75	189	338	529	867	1350	2212
80	200	357	559	916	1426	2337
85	211	376	589	965	1503	2462
90	221	395	619	1014	1579	2588
95	232	414	648	1063	1656	2713
100	243	434	678	1112	1732	2838
105	254	453	708	1161	1808	2963
110	264	472	738	1210	1885	3088
115	275	491	768	1259	1961	3213
120	286	510	798	1308	2038	3339
125	296	529	828	1357	2114	3464
130	307	548	858	1406	2190	3589
135	318	567	888	1455	2267	3714
140	329	586	918	1504	2343	3839
145	339	606	948	1553	2420	3964
150	350	625	978	1602	2496	4090
160	371	663	1037	1700	2649	4340
170	393	701	1097	1798	2802	4590
180	414	739	1157	1897	2954	4841
190	436	778	1217	1995	3107	5091
200	457	816	1277	2093	3260	5341
210	478	854	1337	2191	3413	5592
220	500	892	1396	2289	3566	5842
230	521	931	1456	2387	3718	6092
240	543	969	1516	2485	3871	6343
250	564	1007	1576	2583	4024	6593
260	586	1045	1636	2681	4177	6843
270	607	1084	1696	2779	4329	7094
280	628	1122	1756	2877	4482	7344
290	650	1160	1815	2975	4635	7594
300	671	1198	1875	3074	4788	7845

Note

1. No code stamp or "NB" on nameplate below 15 psig set.

Kunkle Safety and Relief Products

Series 6000

Capacities

Non-code¹ and ASME Section VIII Air [Metric, Nm³/h]

Flow Coefficient = 0.878

Set Pressure [barg]	Orifice Area, cm ²					
	D [0.781]	E [1.394]	F [2.180]	G [3.574]	H [5.567]	J [9.123]
0.2	45	81	126	207	322	528
0.3	55	98	154	252	393	644
0.4	63	113	177	290	452	740
0.6	77	138	215	353	549	900
1.0	104	180	281	461	718	1177
1.5	123	220	345	565	880	1443
2.0	146	261	408	669	1042	1708
2.5	171	305	477	782	1218	1996
3.0	196	350	547	896	1396	2288
3.5	221	394	616	1011	1574	2579
4.0	246	439	686	1125	1752	2871
4.5	271	483	756	1239	1930	3163
5.0	296	528	826	1353	2108	3455
5.5	321	572	895	1468	2286	3746
6.0	346	617	965	1582	2464	4038
6.5	371	662	1035	1696	2642	4330
7.0	396	706	1104	1811	2820	4622
7.5	421	751	1174	1925	2998	4913
8.0	446	795	1244	2039	3176	5205
8.5	471	840	1313	2153	3354	5497
9.0	496	884	1383	2268	3532	5788
9.5	521	929	1453	2382	3710	6080
10.0	545	974	1523	2496	3888	6372
10.5	570	1018	1592	2611	4066	6664
11.0	595	1063	1662	2725	4244	6955
11.5	620	1107	1732	2839	4422	7247
12.0	645	1152	1801	2953	4600	7539
12.5	670	1197	1871	3068	4778	7831
13.0	695	1241	1941	3182	4956	8122
13.5	720	1286	2011	3296	5134	8414
14.0	745	1330	2080	3411	5312	8706
14.5	770	1375	2150	3525	5490	8997
15.0	795	1419	2220	3639	5668	9289
16.0	845	1509	2359	3868	6024	9873
17.0	895	1598	2499	4096	6381	10456
18.0	945	1687	2638	4325	6737	11040
19.0	995	1776	2777	4553	7093	11623
20.0	1045	1865	2917	4782	7449	12207

Note

1. No code stamp or "NB" on nameplate below 1.0 barg set.

Capacities

Non-code¹ and ASME Section VIII Steam (U.S., lb/h)
Flow Coefficient = 0.878

Set Pressure (psig)	Orifice Area, in ²					
	D (0.121)	E (0.216)	F (0.338)	G (0.554)	H (0.863)	J (1.414)
3	87	155	243	398	621	1017
4	100	178	279	457	711	1166
6	121	215	337	552	860	1409
8	137	245	384	629	980	1606
10	152	271	424	695	1083	1775
15	179	319	500	819	1276	2091
20	206	368	576	944	1471	2410
25	234	417	653	1070	1666	2730
30	261	466	729	1195	1861	3050
35	291	520	813	1333	2076	3401
40	321	573	897	1470	2291	3753
45	351	627	981	1608	2505	4105
50	381	681	1065	1746	2720	4456
55	411	734	1149	1884	2934	4808
60	442	788	1233	2022	3149	5160
65	472	842	1317	2159	3364	5511
70	502	896	1401	2297	3578	5863
75	532	949	1486	2435	3793	6215
80	562	1003	1570	2573	4008	6566
85	592	1057	1654	2710	4222	6918
90	622	1110	1738	2848	4437	7270
95	652	1164	1822	2986	4651	7621
100	682	1218	1906	3124	4866	7973
105	712	1272	1990	3262	5081	8325
110	742	1325	2074	3399	5295	8676
115	773	1379	2158	3537	5510	9028
120	803	1433	2242	3675	5725	9380
125	833	1487	2326	3813	5939	9731
130	863	1540	2410	3950	6154	10083
135	893	1594	2494	4088	6368	10434
140	923	1648	2578	4226	6583	10786
145	953	1701	2662	4364	6798	11138
150	983	1755	2746	4502	7012	11489
160	1043	1863	2915	4777	7442	12193
170	1104	1970	3083	5053	7871	12896
180	1164	2077	3251	5328	8300	13599
190	1224	2185	3419	5604	8729	14303
200	1284	2292	3587	5879	9159	15006
210	1344	2400	3755	6155	9588	15709
220	1404	2507	3923	6430	10017	16413
230	1465	2615	4091	6706	10446	17116
240	1525	2722	4259	6981	10876	17819
250	1585	2829	4428	7257	11305	18523
260	1645	2937	4596	7533	11734	19226
270	1705	3044	4764	7808	12163	19929
280	1766	3152	4932	8084	12592	20632
290	1826	3259	5100	8359	13022	21336
300	1886	3367	5268	8635	13451	22039

Note

1. No code stamp or "NB" on nameplate below 15 psig set.

Capacities

Non-code¹ and ASME Section VIII Steam [Metric, kg/h]

Flow Coefficient = 0.878

Set Pressure [barg]	Orifice Area, cm ²					
	D [0.781]	E [1.394]	F [2.180]	G [3.574]	H [5.567]	J [9.123]
0.2	39	69	108	177	276	453
0.3	47	84	131	215	335	549
0.4	54	96	150	246	383	628
0.6	65	115	181	296	461	756
1.0	81	144	226	370	576	944
1.5	98	175	273	448	698	1144
2.0	116	207	324	530	826	1354
2.5	135	242	378	620	966	1582
3.0	155	277	433	711	1107	1814
3.5	175	312	489	801	1248	2045
4.0	195	348	544	892	1389	2276
4.5	215	383	599	982	1530	2508
5.0	234	419	654	1073	1671	2739
5.5	254	454	710	1164	1812	2970
6.0	274	489	765	1254	1954	3201
6.5	294	525	820	1345	2095	3433
7.0	314	560	876	1435	2236	3664
7.5	333	595	931	1526	2377	3895
8.0	353	631	986	1617	2518	4127
8.5	373	666	1041	1707	2659	4358
9.0	393	701	1097	1798	2800	4589
9.5	413	737	1152	1888	2942	4820
10.0	432	772	1207	1979	3083	5052
10.5	452	807	1262	2070	3224	5283
11.0	472	843	1318	2160	3365	5514
11.5	492	878	1373	2251	3506	5746
12.0	512	913	1428	2341	3647	5977
12.5	531	949	1483	2432	3788	6208
13.0	551	984	1539	2523	3929	6439
13.5	571	1019	1594	2613	4071	6671
14.0	591	1055	1649	2704	4212	6902
14.5	611	1090	1705	2795	4353	7133
15.0	630	1125	1760	2885	4494	7365
16.0	670	1196	1870	3066	4776	7827
17.0	710	1267	1981	3248	5059	8290
18.0	749	1337	2091	3429	5341	8752
19.0	789	1408	2202	3610	5623	9215
20.0	829	1479	2313	3791	5905	9678

Note

1. No code stamp or "NB" on nameplate below 1.1 barg set.

Capacities

ASME Section I Steam (U.S., lb/h)

Flow Coefficient = 0.878

Set Pressure (psig)	Orifice Area, in ²					
	D (0.121)	E (0.216)	F (0.338)	G (0.554)	H (0.863)	J (1.414)
15	173	310	484	794	1237	2027
20	201	358	561	919	1432	2346
25	228	407	637	1045	1627	2666
30	256	456	714	1170	1822	2986
35	283	505	790	1295	2017	3306
40	310	554	867	1420	2213	3625
45	338	603	943	1546	2408	3945
50	365	651	1019	1671	2603	4265
55	392	700	1096	1796	2798	4584
60	420	749	1172	1921	2993	4904
65	447	798	1249	2047	3188	5224
70	475	848	1327	2174	3387	5550
75	503	898	1405	2303	3588	5879
80	531	948	1484	2432	3789	6208
85	559	999	1563	2561	3990	6538
90	588	1049	1641	2690	4191	6867
95	616	1099	1720	2819	4392	7196
100	644	1150	1799	2948	4593	7525
105	672	1200	1878	3077	4794	7855
110	700	1250	1956	3206	4995	8184
115	728	1300	2035	3335	5196	8513
120	757	1351	2114	3464	5397	8842
125	785	1401	2192	3593	5598	9172
130	813	1451	2271	3722	5799	9501
135	841	1502	2350	3851	6000	9830
140	869	1552	2429	3980	6201	10160
145	898	1602	2507	4109	6402	10489
150	926	1653	2586	4238	6603	10818
160	982	1753	2743	4497	7004	11477
170	1038	1854	2901	4755	7406	12135
180	1095	1954	3058	5013	7808	12794
190	1151	2055	3216	5271	8210	13452
200	1208	2156	3373	5529	8612	14111
210	1264	2256	3530	5787	9014	14769
220	1320	2357	3688	6045	9416	15428
230	1377	2457	3845	6303	9818	16087
240	1433	2558	4003	6561	10220	16745
250	1489	2659	4160	6819	10622	17404
260	1546	2759	4318	7077	11024	18062
270	1602	2860	4475	7335	11426	18721
280	1658	2960	4632	7593	11828	19379
290	1715	3061	4790	7851	12230	20038
300	1771	3162	4947	8109	12632	20696

Kunkle Safety and Relief Products

Series 6000

Capacities

ASME Section I Steam [Metric, kg/h]

Flow Coefficient = 0.878

Set Pressure [barg]	Orifice Area, cm ²					
	D [0.781]	E [1.394]	F [2.180]	G [3.574]	H [5.567]	J [9.123]
1.5	95	170	266	437	680	1115
2.0	113	202	317	519	809	1325
2.5	131	235	367	601	937	1535
3.0	149	267	417	684	1065	1746
3.5	167	299	467	766	1193	1956
4.0	185	331	518	849	1322	2166
4.5	203	363	568	931	1450	2376
5.0	222	396	619	1015	1581	2592
5.5	240	429	671	1100	1714	2808
6.0	259	462	723	1185	1846	3025
6.5	277	495	775	1270	1978	3241
7.0	296	528	826	1355	2110	3458
7.5	315	561	878	1440	2242	3675
8.0	333	595	930	1524	2374	3891
8.5	352	628	982	1609	2507	4108
9.0	370	661	1033	1694	2639	4324
9.5	389	694	1085	1779	2771	4541
10.0	407	727	1137	1864	2903	4757
10.5	426	760	1189	1949	3035	4974
11.0	444	793	1240	2033	3167	5191
11.5	463	826	1292	2118	3300	5407
12.0	481	859	1344	2203	3432	5624
12.5	500	892	1396	2288	3564	5840
13.0	519	925	1447	2373	3696	6057
13.5	537	959	1499	2458	3828	6273
14.0	556	992	1551	2542	3960	6490
14.5	574	1025	1603	2627	4092	6707
15.0	593	1058	1654	2712	4225	6923
15.5	611	1091	1706	2797	4357	7140
16.0	630	1124	1758	2882	4489	7356
16.5	648	1157	1810	2967	4621	7573
17.0	667	1190	1861	3052	4753	7789
18.0	704	1256	1965	3221	5018	8223
19.0	741	1323	2068	3391	5282	8656
20.0	778	1389	2172	3561	5546	9089

Capacities

ASME Section IV Steam, lb/h [kg/h] - Models 6933, 6934 and 6935

Set Pressure (psig) [barg]	Orifice, Area in ² [cm ²]					
	D	E	F	G	H	J
	0.121 [0.781]	0.216 [1.394]	0.338 [2.180]	0.554 [3.574]	0.863 [5.567]	1.414 [9.123]
15 [1.0]	190 [86]	339 [153]	530 [240]	869 [394]	1353 [613]	2217 [1004]

Specifications

Service Recommendations for Series 6000 Resilient Seat/Seal Materials

Seat/Seal Materials	Service Recommendation
Viton® A (-15 to 406°F) [-26 to 208°C]	Air and Gas
Ethylene Propylene (-70 to 425°F) [-57 to 218°C]	Steam
Teflon®	Steam

