

The **DFT® Model SCV Check Valve** is a corrosion-resistant, dependable, versatile and economical spring-assisted, non-slam check valve for a wide range of applications. Whether the fluid is liquid, gas or steam, the SCV provides tight shutoff and protects other equipment in the system from water hammer. Its stainless steel construction assures a long service life.



FEATURES:

- 1/2" to 3" Line size
- 750 & 3600 CWP
- NPT & SW ends
- Stainless steel construction
- Inconel® X-750 spring
- Spring-assisted silent closing, non-slam
- Zelon® "O" ring body seal
- Horizontal or vertical installation
- Body-guided disc
- Tight shutoff lapped disc & seat
- Simplified 5-part construction
- Easy maintenance
- Versatile
- Options:
 - 316 SS springs
 - Body seal weld
 - Soft seat
 - Alloy 20 body & seat (ASME 300)
 - Hastelloy® C body & seat (ASME 300)
 - NPT x socket weld ends
 - SCV-R (higher cracking pressure)
 - Butt weld ends
 - NACE (Page 39)

MATERIALS OF CONSTRUCTION

COMPONENT	750 CWP	3600 CWP
Body	A351 CF8M	A351 CF8M
Seat (1)	A351 CF8M	A351 CF8M
Disc	A240 316	A240 316
Spring	Inconel® X-750	Inconel® X-750
Body Seal (7)	Standard: Zelon (470°F max.)	Standard: Zelon (400°F max.)(2)
	Option: Body seal weld (700°F max.)	Option: Body seal weld (700°F max.)

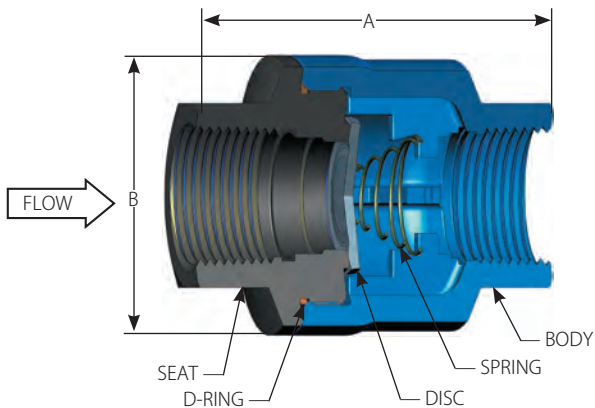

Class	750 CWP/ 500 CWP	3600 CWP	
1/2"	A	2.68	3.16
	B	1.62	1.88
	Weight	1.1	1.5
	Cv	7	6
3/4"	CP	0.29	0.62
	A	3	3
	B	2.13	2.33
	Weight	1.5	3
1"	Cv	13	11
	CP	0.24	0.26
	A	3.32	3.75
	B	2.54	2.75
1 1/4"	Weight	1.9	4.5
	Cv	22	19
	CP	0.36	0.36
	A	3.87	
1 1/2"	B	3.06	
	Weight	3.9	
	Cv	39	
	CP	0.28	
2"	A	4.75	6.38
	B	3.44	4.31
	Weight	4.7	14.0
	Cv	54	65
3"	CP	0.24	0.36
	A	5	
	B	4.4	
	Weight	7.7	
3"	Cv	93	
	CP	0.42	
	A	6.75	
	B	6.19	
3"	Weight	18.8	
	Cv	180	
	CP	0.20	

PRESSURE TEMPERATURE RATING (PSIG) (3)

Temp. (F°)	A351 CF8M		Alloy 20 (CN7M)	Hastelloy C (CW-12MW)
	750 CWP	3600 CWP	ASME 300	ASME 300
100	750	3600	600	600
200	645	3095	520	550
250 (4)	610	2945	490	535
300	580	2795	465	520
400 (5)	535	2570	420	490
470 (6)	510			

- Notes:**
1. Soft seats are available for bubble-tight shutoff. See above. Body seal and soft seat material are the same unless otherwise requested.
 2. Buna-N CO₂ resistant "O" ring is available upon request.
 3. ASME B16.34-2004

4. Maximum temperature for Buna-N.
5. Maximum temperature for Viton® and Zelon w/3600 CWP SCV.
6. Maximum temperature for Zelon w/750 CWP SCV.
7. Only Zelon is recommended for steam service.

All dimensions are in inches. Weights are in pounds. CP: Cracking Pressure (psig)